

IX-DVF-6

INSTALLATION AND PROGRAMMING GUIDE

The IX-DVF-6 is an IX Series video door station with 6 call buttons for selective calling to IX-MV7 master stations. The IX-DVF-6 will connect to a network switch, and the call buttons are connected to contact inputs on the station. These inputs will be programmed to selectively call different master stations, or groups of master stations.

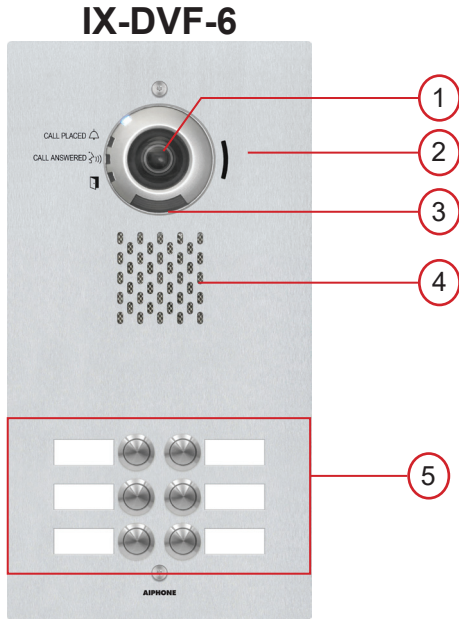

Names and Functions

1. Camera
2. Microphone
3. White LED for night viewing
4. Speaker
5. Call buttons

Features

- IP video door station
- 6 Labeled Call Buttons
- Stainless steel faceplate with tamper resistant screws

PACKAGE CONTENTS



IX-DVF-6
Door Station



Flush mount backbox and
mounting bracket



2 Security Screws
4 Bracket Screws



Security Driver

Label Template
Page



Door Release
wire harness

Installation

For flush mounting, recess the supplied back box into the wall, then attach the mounting bracket using the four provided bracket screws.

Back Box Dimensions: 12-1/2" H x 6-1/8" W x 2-3/8" D
IX-DVF-6 Dimensions: 13-11/16" H x 7-3/16" W

For surface mounting, use the SBX-IXGDM7 surface mount box. This box can mount to a standard single gang box or to any flat surface.

To install the labels, cut along the template guides, then slide each side in to the label space on the panel.

Wiring Diagram

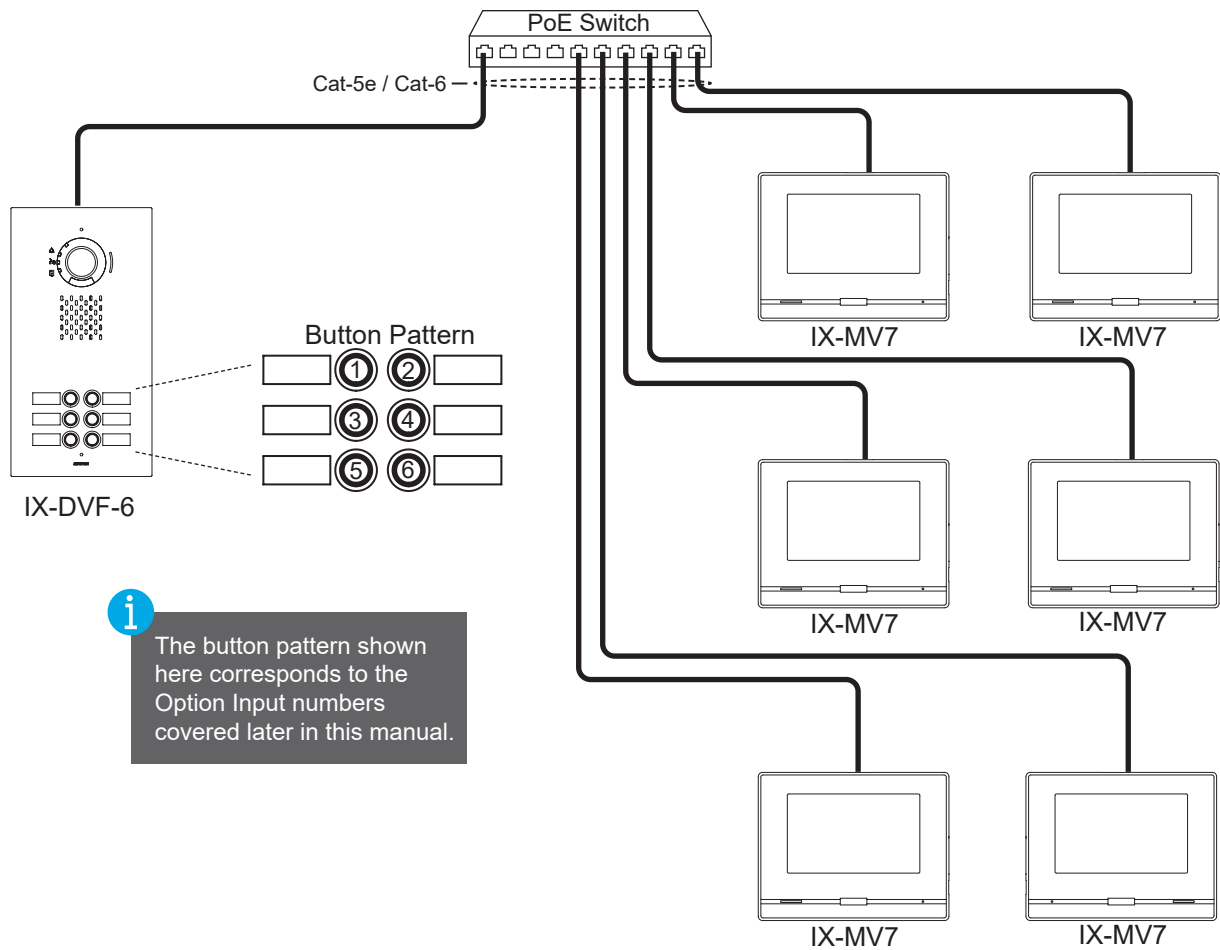

i The button pattern shown here corresponds to the Option Input numbers covered later in this manual.

Specifications

Camera unit:	1/3" color CMOS 1.2 megapixel
Min. illumination:	5 Lux
Terminations:	RJ45
Operating Temp:	-40° ~ 140°F / -40° ~ 60°C
Wiring Distance:	328' with CAT-5e/6 cable to switch
Dimensions:	13-11/16" H x 7-3/16" W
w/ SBX-IXGDM7:	13-3/4" H x 7-5/16" W x 3-1/16" D

FCC WARNING:

This device complies with Part 15 of the FCC rules.

Operation is subject to the following two conditions:

(1) This device may not cause harmful interference.

(2) This device must accept any interference that may cause undesired operation.

- For proper regulatory compliance, the drain wire should be disconnected at the power supply end of the cable.
- Changes or modifications not expressly approved by the party responsible for compliance could void the user's authority to operate the equipment.

Getting Started

This programming guide will cover how to program an IX-DVF-6 door station and IX-MV7 master stations using the IX Support Tool software. For additional information and documentation for the IX system, please visit www.aiphone.com/IX.

Creating a New System

Open the IX Support Tool, then select **File** from the top menu and click **Create New System**. Enter in a System Name, and select the **No** radial button for Wizard Programming. Enter a system ID and Password. Enter station quantities and then click **Finish**.

New System

System Settings

System Name:

IP Version:

Enter contact information (optional):

Installer Information:

Displays in CONTACT INFORMATION of IX-MV7-*, IX-SOFT.

Owner Information:

Notes:

Expanded System

Wizard Programming

Yes No

Automatically configure door release for all stations?

Yes No

System ID: 1-20 alphanumeric characters

System Password: 1-20 alphanumeric characters

IX Support Tool Settings

Enter the number of stations

Master Stations

IX-MV7-* Station(s)

IX-MV Station(s)

IX-SOFT Station(s)

Video Stations

IX-DV, IX-DVF(-*) Station(s)

IX-DVM Station(s)

IX-EA, IX-EAU Station(s)

IX-DA Station(s)

Audio Stations

IX-SSA(-*) Station(s)

IX-SS-2G Station(s)

IX-FA Station(s)

IX-SPMIC Station(s)

IX-BA Station(s)

IX-RS-* Station(s)

Others

IXW-MA Station(s)

Buttons: Restore Setting File, Import System Configuration, Finish, Cancel



The IX-DVF-6 counts as an IX-DV, IX-DVF(-*) station in this section.

Station Information

Support Tool will open in Table View on the **Station Information - Identification** page. Enter unique Station Numbers and Names for each station. Click **Update** to save the changes.

AIPHONE IX Support Tool

Update

Table View | Remove Station | Location Registry

Station View

Number of Notes: 2

1. Locations must be created in the Location Registry before they can be assigned to a Station.
2. Station Type cannot be changed once registered. To modify, station must be removed.

Station Information

Identification

Text in red are required setting

#	Number	Name	Location	Station Type
0001	101	Tenant 1		IX-MV7-*
0002	102	Tenant 2		IX-MV7-*
0003	103	Tenant 3		IX-MV7-*
0004	104	Tenant 4		IX-MV7-*
0005	200	Front Door		IX-DV, IX-DVF(-*)

Station Information

- Identification
- ID and Password
- Time
- Expanded System
- Network Settings
- System Information
- Call Settings
- Option Input / Relay Output S
- Paging Settings
- Function Settings
- Transfer Settings

Network Settings - IP Address

The IP addresses for the stations can be individually set for each station or they can be configured in a batch. This guide will show how to assign via the batch configuration. Expand **Network Settings** and click on **IP Address**, then click **Batch IP Address Configuration**

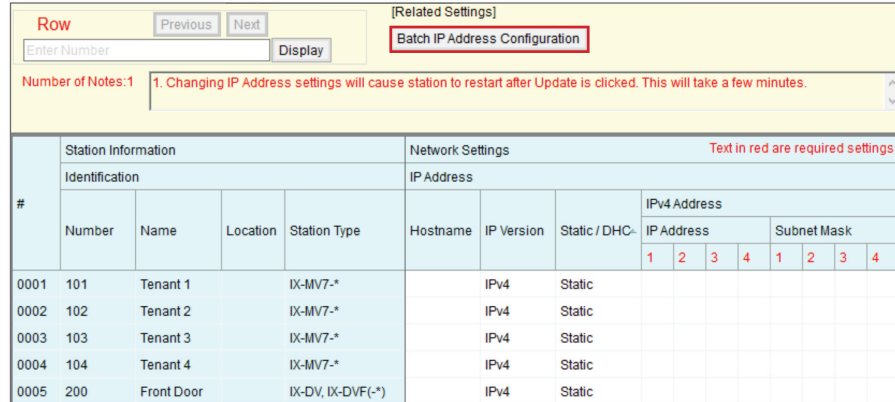
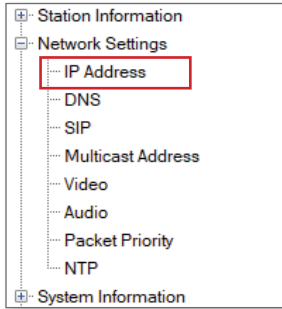

Batch IP Address Configuration

On the Batch IP Address Configuration page, enter a starting IP address and subnet mask. Check the box beside each station or click **Select** to check all stations at once. Click **OK**, then click **OK** on the confirmation pop-up. Each station will now have an IP address and Subnet Mask assigned to it.

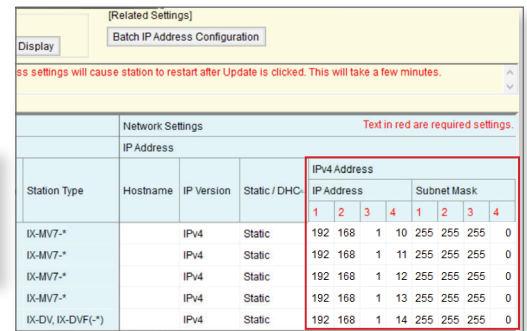
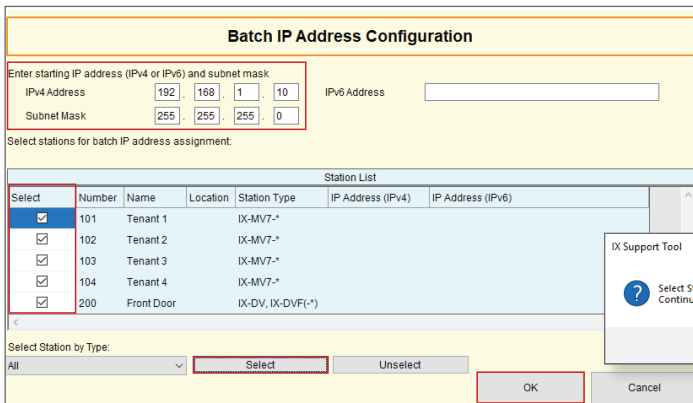

i If a Default Gateway address is required, it can be manually added on this page once the IP addresses have been assigned.

Association Settings

The station name and IP address that were assigned in the previous steps will now need to be associated to each station in the system before any call settings can be uploaded. From the top menu bar, select **Tools(T)** from the top menu, then click **Association Settings**.

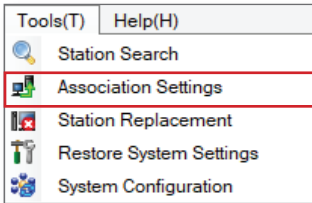

When the Association Settings window opens, it will automatically begin searching for any IX stations on the network. Once this is complete, select a configuration in the Station Settings List at the top, then select the station to assign it to in the Station List. Click **Apply** and **OK** on the pop-up to start the association process for that station, then repeat these steps for the remaining stations.

Station Settings List							
Select	Number	Name	Location	Station Type	Hostname	IP Address	Associated
<input checked="" type="radio"/>	101	Tenant 1		IX-MV7-*		192.168.1.10	-
<input type="radio"/>	102	Tenant 2		IX-MV7-*		192.168.1.11	-
<input type="radio"/>	103	Tenant 3		IX-MV7-*		192.168.1.12	-
<input type="radio"/>	104	Tenant 4		IX-MV7-*		192.168.1.13	-
<input type="radio"/>	200	Front Door		IX-DV, IX-DVF(-*)		192.168.1.14	-

2. Select the station to associate with the setting file.

Enter station MAC address: Different Networks

Search and select station within local network:

Station List						
Select	Number	Name	Location	Station Type	MAC address	Associated
<input checked="" type="radio"/>				IX-MV7-*	00:0B:AA:2F:02:1A	-
<input type="radio"/>				IX-MV7-*	00:0B:AA:2F:02:2D	-
<input type="radio"/>				IX-MV7-*	00:0B:AA:2F:01:AC	-
<input type="radio"/>				IX-MV7-*	00:0B:AA:2F:02:DB	-
<input type="radio"/>				IX-DV, IX-DVF(-*)	00:0B:AA:27:03:1A	-

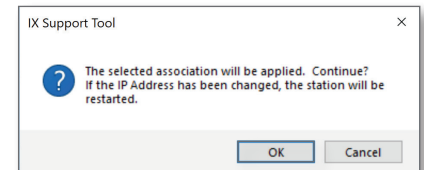

Apply



If the Station Search fails to find any stations, verify that the stations are powered on and that the PC is connected to the same switch.

Once associated, the stations will restart with the IP address and station name assigned. Scroll down to the Associated Stations List at the bottom of the page to confirm the status of the association.

Associated Stations List							
Select	Number	Name	Location	Station Type	IP Address	MAC address	Status
<input type="checkbox"/>	101	Tenant 1		IX-MV7-*	192.168.1.10	00:0B:AA:2F:02:1A	Success
<input type="checkbox"/>	102	Tenant 2		IX-MV7-*	192.168.1.11	00:0B:AA:2F:02:2D	Success
<input type="checkbox"/>	103	Tenant 3		IX-MV7-*	192.168.1.12	00:0B:AA:2F:01:AC	Success
<input type="checkbox"/>	104	Tenant 4		IX-MV7-*	192.168.1.13	00:0B:AA:2F:02:DB	Success
<input type="checkbox"/>	200	Front Door		IX-DV, IX-DVF(-*)	192.168.1.14	00:0B:AA:27:03:1A	Success

Call Button Settings - Option Inputs

The IX-DVF-6 has six call buttons that are wired to Option Inputs. These inputs will need to be programmed to place a call. Click on **Station View**, then expand **Option Input/Relay Output Settings** and select **Option Input**.

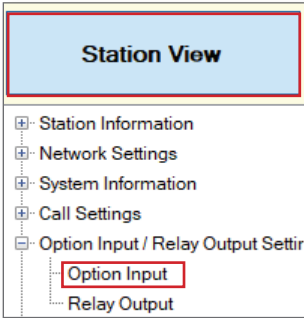

Option Inputs

In the **Select Station to Edit** menu, use the **Number** drop-down to select the IX-DVF-6, then click **Select**. Use the **Option Input** drop-down to select **Option Input 1**. Click the **Call** radial button, then click **Update**. Use the **Option Input** drop-down to switch to the next Option Input and repeat this process until all of the inputs have been set to **Call**.

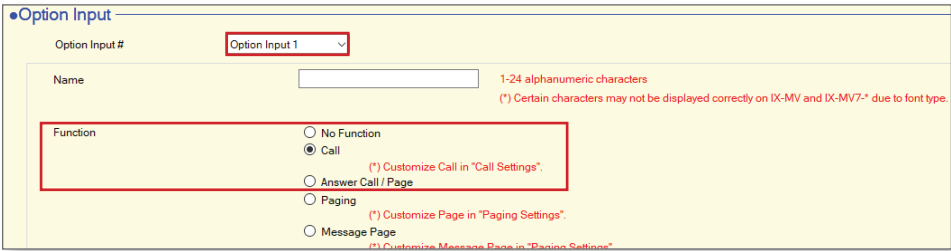
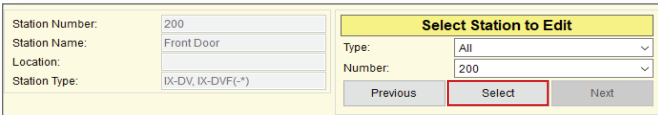

Called Stations Groups

Once the Option Inputs are set to call, individual Called Station Groups will be assigned to each to allow for selective calling from each button. Expand **Call Settings** and click **Called Stations (Door/Sub Stations)**. Use the **Group Number** drop-down to select **Group 01**.

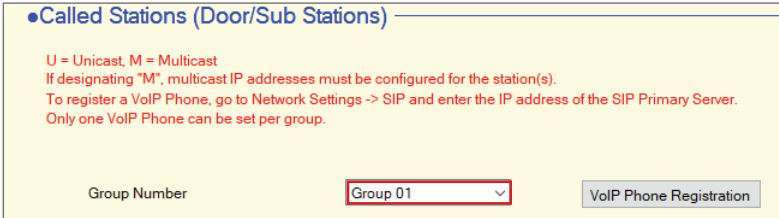
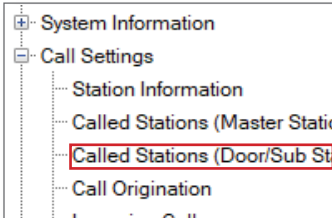

Each of the Called Stations groups will be call to a different master group of masters. Use the **Open** and **Delete** buttons to add or remove master stations from the list. When one group is complete, click on **Update** and then switch to the next group using the **Group Number** drop-down. Repeat until a call group has been configured for each button that will be in use.

#	Number	Station List	IPv4 Address	IPv6 Address	Station Type	Protocol	Delete
01	101	Open	192.168.1.10		IX-MV7-*	U	Delete
02	102	Open	192.168.1.11		IX-MV7-*	U	Delete
03	103	Open	192.168.1.12		IX-MV7-*	U	Delete
04	104	Open	192.168.1.13		IX-MV7-*	U	Delete
05	105	Open	192.168.1.14		IX-MV7-*	U	Delete
06	106	Open	192.168.1.15		IX-MV7-*	U	Delete



Programming Call Buttons

To link the Called Stations groups to the call buttons on the door station, expand **Call Settings** and click on **Call Origination**. Use the **Call Button / Option Input #** drop-down and select **Option Input 1**.

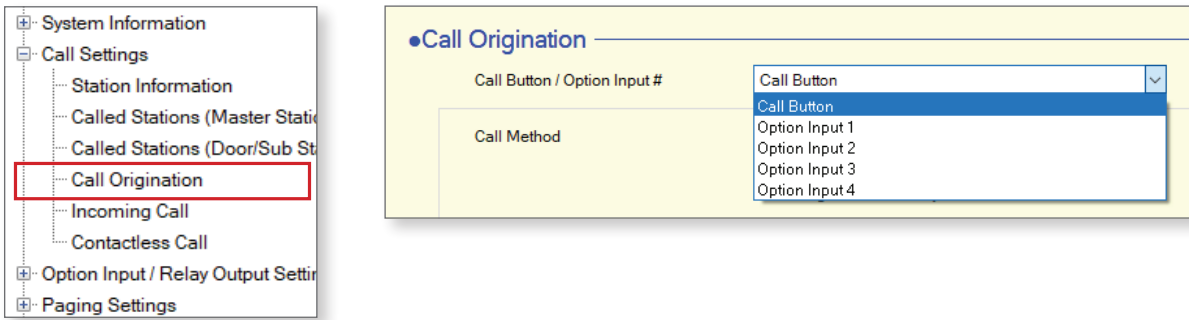

Use the **Standard Mode Settings - Call Destination** drop-down to assign a call group to the Option Input. Press **Update** when a call group has been set, then switch to the next Option Input and repeat until all of the Option Inputs that will be used have a call group linked to them.

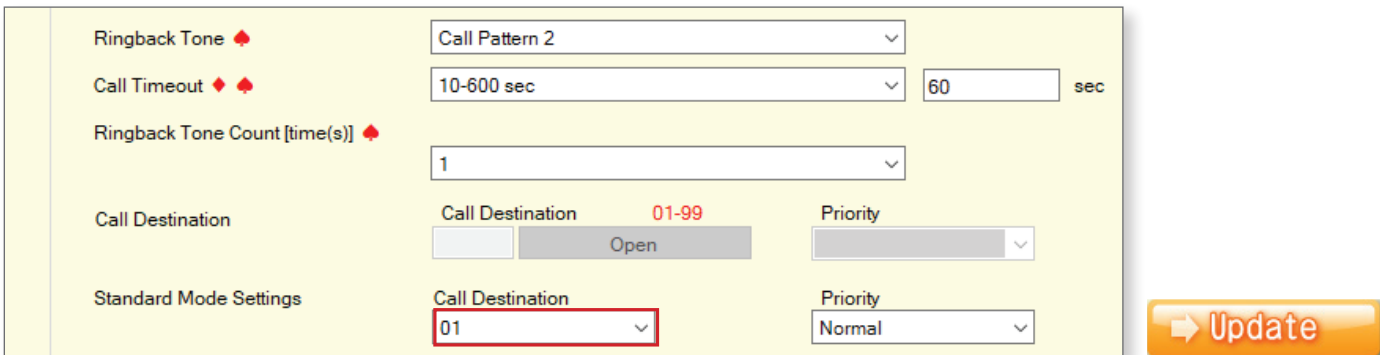

Setting File Upload

Once all settings are configured, select **File (F)** from the top bar and select **Upload Settings to Station**. Click **Select** to check all of the stations, then click on **Settings**. Once **OK** is pressed on the confirmation pop-up, the upload process will start. This process will take around 30 seconds to a minute. Once it is complete, confirm that the Status column shows Success for each station.

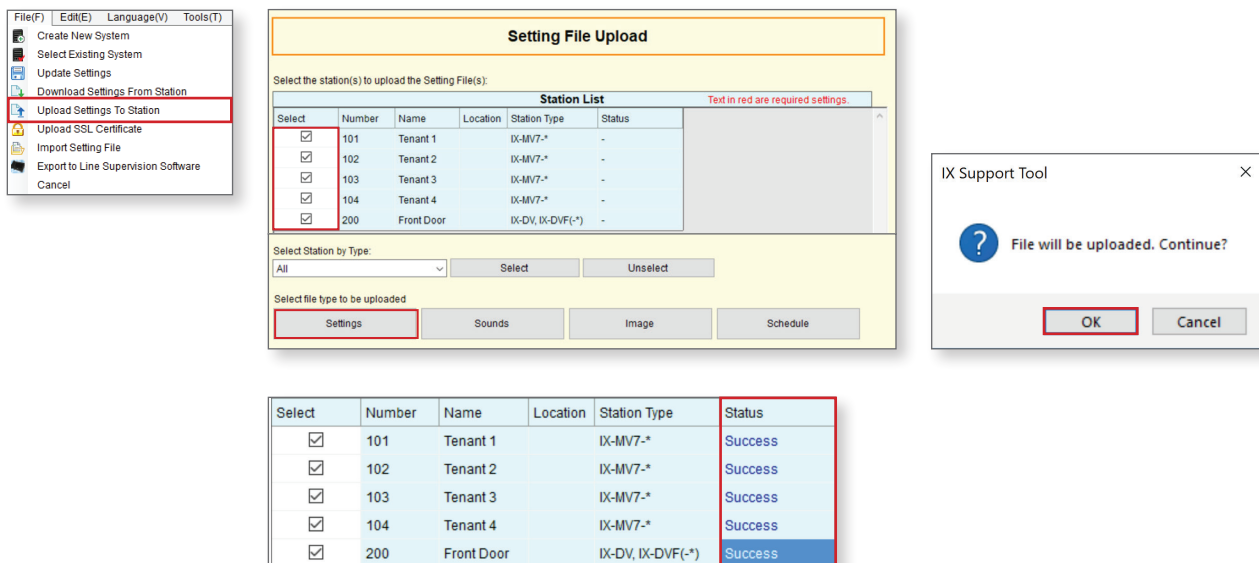

For more details about the features and information above, please contact Technical Support.